

HIGH PRODUCTIVITY 4-AXIS TURNING CENTER

PUMA TL 2000·2500

PUMA TL 2000/L/M/LM

PUMA TL 2500/L/XL/M/LM/XLM



PUMA TL 2000·2500

The PUMA TL2000/2500 series has been engineered to increase productivity by delivering high efficiency. As a process-integrated machine the PUMA TL provides customers with new levels of performance and best-in-class machining capabilities.

CONTENTS

Product Overview

Basic Information

- 04 Basic Structure
- 05 Machining Area
- 06 Spindle
- 07 Turret

Detailed Information

- 08 Standard | Optional Specifications
- 09 Peripheral Equipment
- 10 FANUC i PLUS
- 12 Power | Torque
- 13 External Dimensions
- 16 Tooling System
- 18 Tool Interface
- 19 Working Range
- 20 Machine Specifications

Customer Support Service

- 21 Why DN Solutions
- 22 Customer Support and Services
- 23 Global Network



**HIGH PERFORMANCE, HIGH
PRODUCTIVITY MACHINING**



These machines have class-leading machining capabilities that provide unrivalled performance and productivity for customers.

MACHINING FLEXIBILITY



Provides outstanding performance, accuracy and productivity thanks to parts being machined, to completion, in single set ups.

**POWERFUL BUILT-IN
SPINDLE MOTOR**



The powerful built-in spindle motor enables a wide range machining operations to be performed - from heavy-duty cutting and high metal removal, through to super fine finishing using both turrets at the same time.



BASIC STRUCTURE

The combination of an integrated, high-performance spindle motor with upper and lower multi-axis turrets has resulted in a machine perfectly engineered for high productivity and optimum efficiency.

The 4-axis linear-controlled machine delivers multi-axis performance and simultaneous control of both turrets to enable the efficient machining of shaft type workpieces.

Travel distance

X1-axis

250 mm (9.8 inch)

X2-axis

150 mm (5.9 inch)

Z1-axis

650 {1050/1300 OPTION} mm
(25.6 {41.3/51.2} inch)

Z2-axis

630 {1030/1280 OPTION} mm
(24.8 {40.6/50.4} inch)

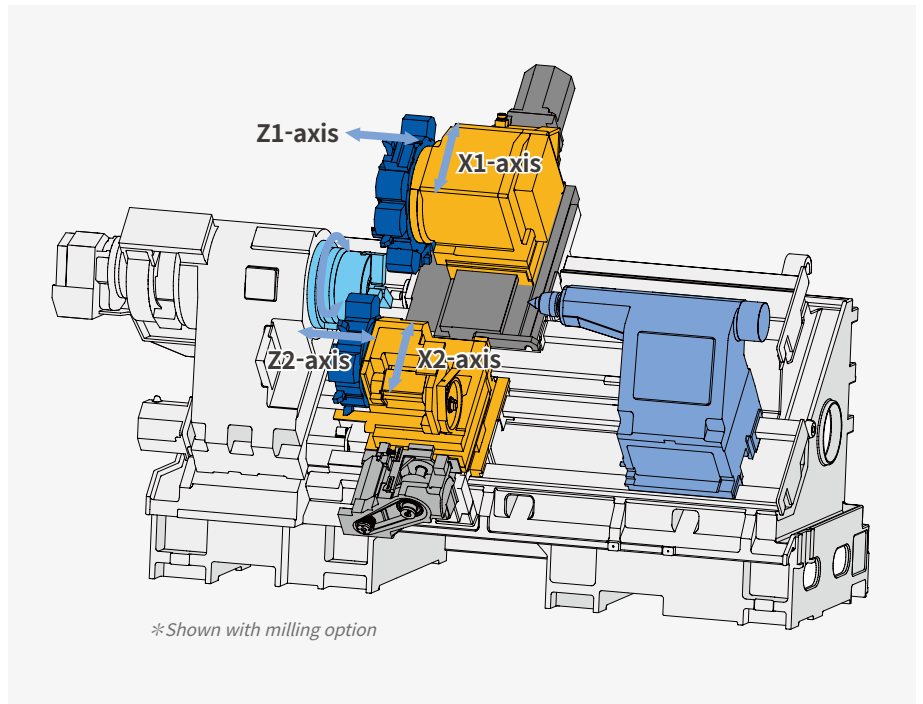

ROBUST DESIGN

The heavily ribbed triangular torque frame is able to withstand eccentric loads.

A 45° inclined wall is inserted into the triangular frame, under the center, to withstand high stresses caused by Xdirection forces.

FEM
Structural
Analysis

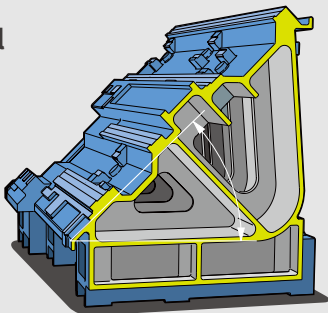

Torque tube
triangular
frame

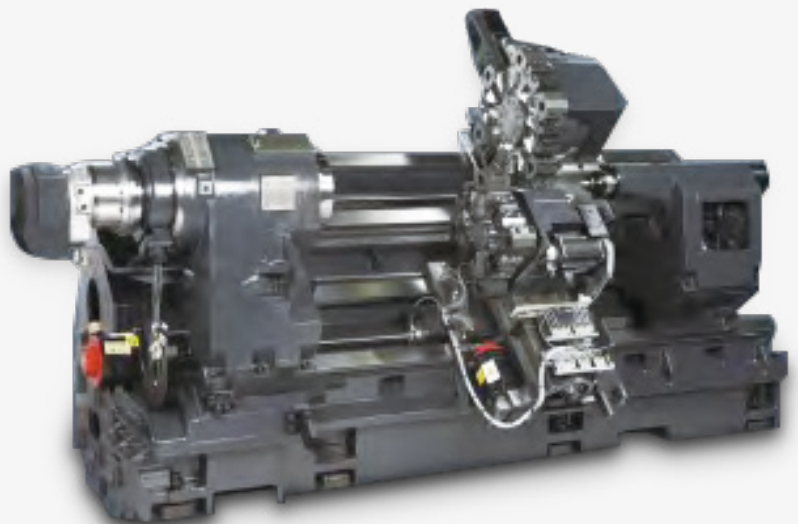
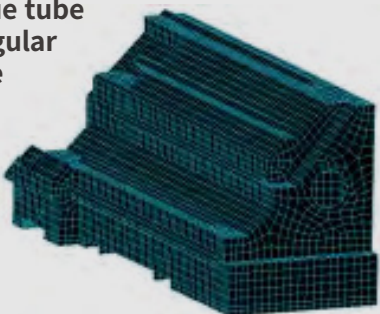

MACHINING AREA

PUMA TL series machines feature the largest machining areas in their class and deliver high productivity and cost efficiencies.

(A) Max. turning diameter
(upper / lower turret)

PUMA TL 2000[L] · PUMA TL2500[L/XL]

370/240 mm
(14.6/9.4 inch)

(B) Max. turning length

600 {1000/1250 OPTION} mm
(23.6 {39.4/49.2} inch)

*{ } : Long bed models

Max. bar working diameter

Ø65/81 mm
(Ø2.6/3.2 inch)

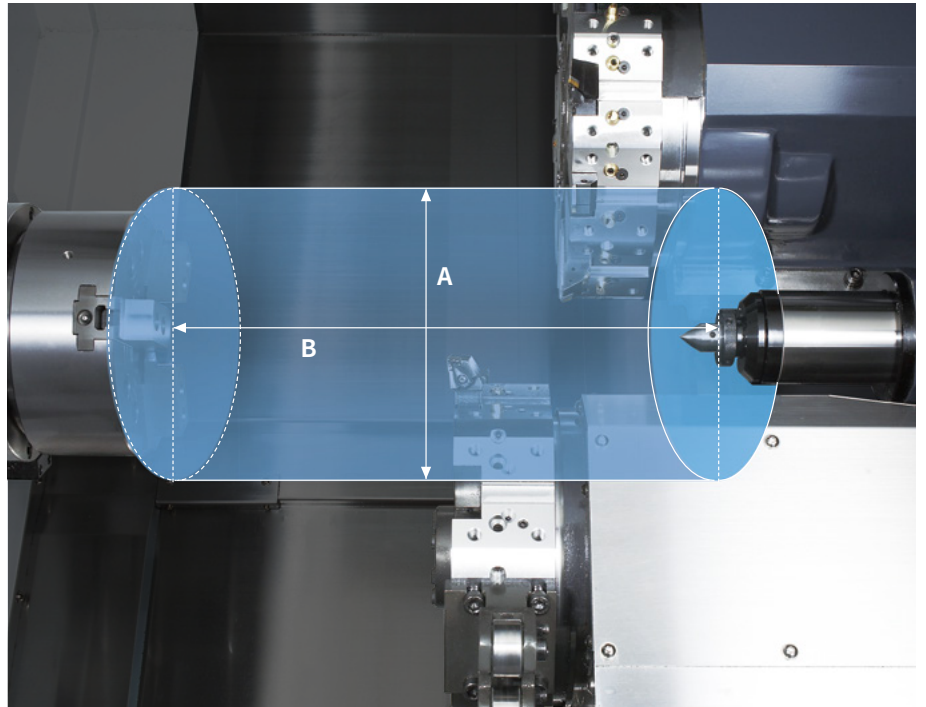

MACHINING FLEXIBILITY

- Accuracy and time savings achieved from single set-ups.
- Unmanned operation achieved through automation.
- Less floor space and increased productivity.

Long shaft working with steady rest prevents chatter

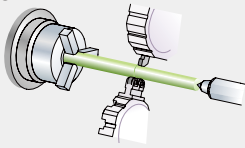

Balanced 4-axis turning

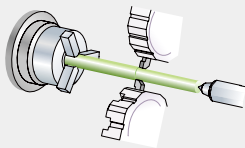

Simultaneous 4-axis turning

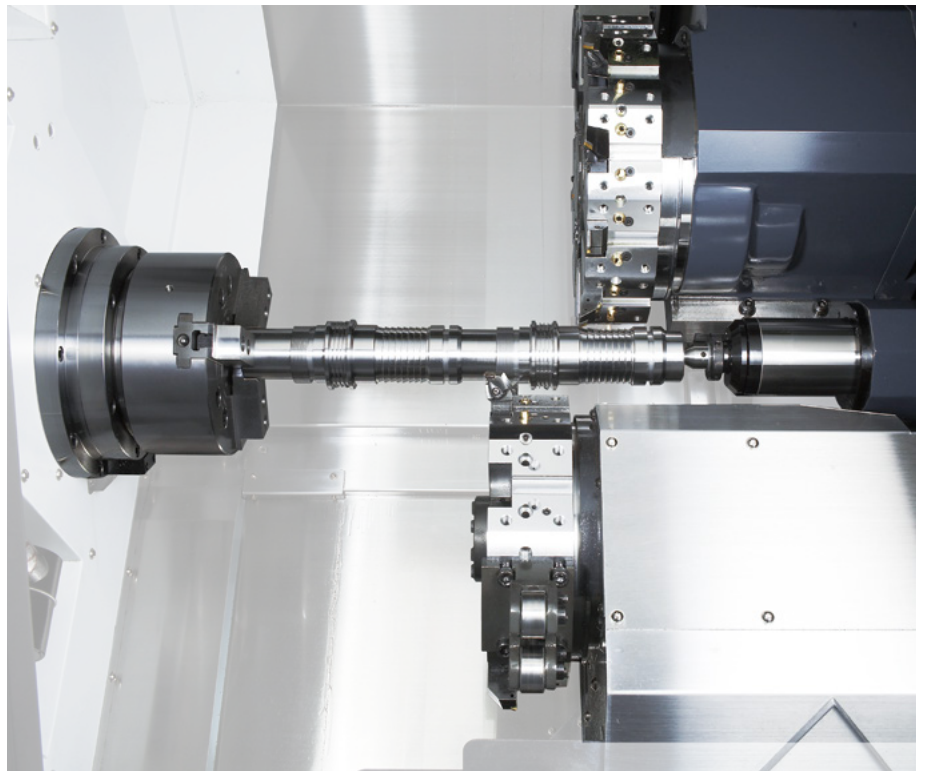
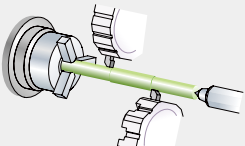

SPINDLE

The powerful built-in spindle motor enables a wide range of machining operations to be undertaken, from precise finishing to high metal removal using both turrets at the same time.

Max. spindle speed

PUMA TL2000/2000M

5000 r/min

PUMA TL2500/2500M

4000 r/min

Max. spindle motor power

PUMA TL2000 Series

22 / 18.5 / 15 kW
(29.5/24.8/20.1 Hp)

(S6 15%/S6 25%/S2 30min/S1 Cont.)

PUMA TL2000 Series

26 / 22 / 15 kW
(34.9/29.5/20.1 Hp)

(S6 25%/S2 30min/S1 Cont.)

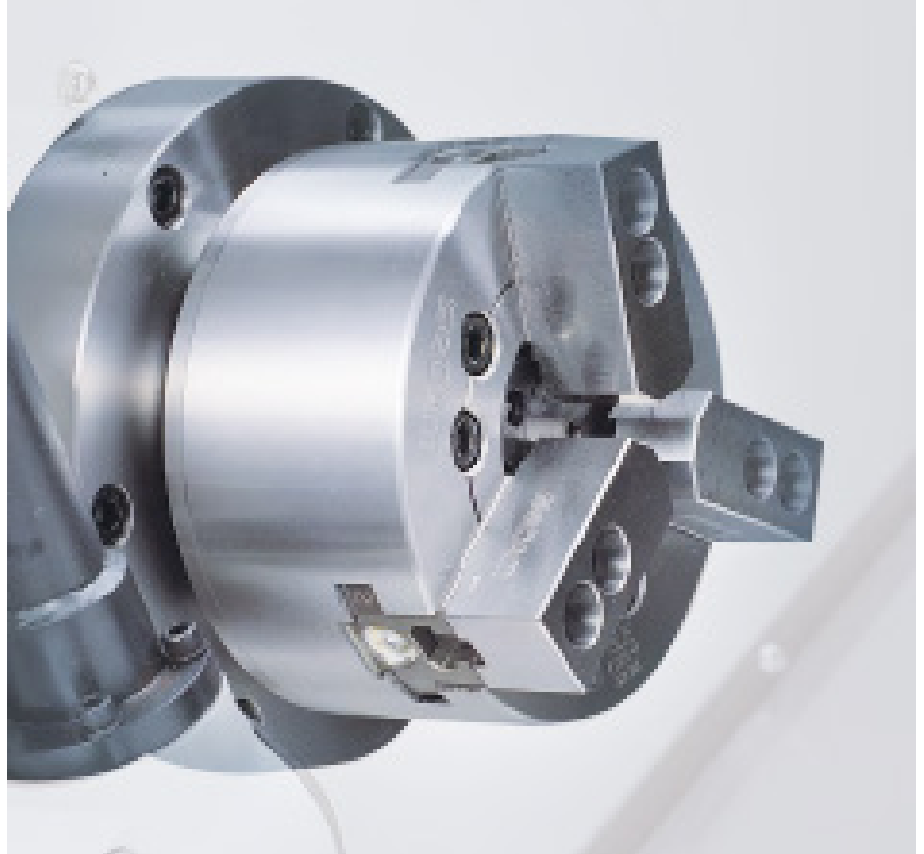

Oil cooling unit for spindles

The spindle motor is surrounded by an oil jacket cooling system that helps minimize thermal displacement and ensures temperature consistency, irrespective of cutting conditions.

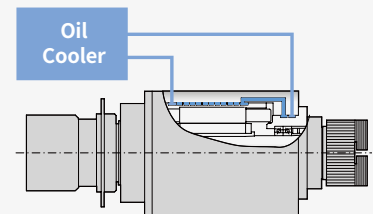

TAIL STOCK

The widely spaced guideways and heavy-duty tailstock design deliver unsurpassed rigidity and reliability. The tailstock is positioned by a drive bar that engages with the carriage.

Tail stock quill type	-	MT#5
Tail stock quill diameter	mm (inch)	100 (3.9)
Tail stock quill travel	mm (inch)	120 (4.7)
Tail stock quill thrust force	kN	8.8

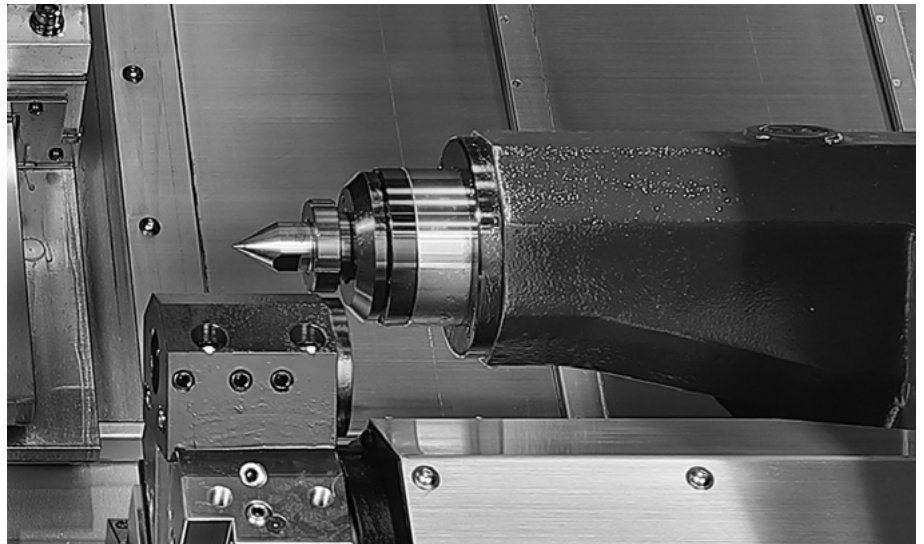

TURRET

Rotation of the turret is controlled by a servo-driven motor that ensures rapid and accurate tool selection. The M model features the unique BMT turret that provides superior performance in milling operations.

A total of 20 tool stations in the upper and lower turrets makes it possible to complete complicated parts, requiring many tools, in just one set-up. Reliable servo driven turrets reduce total cycle times required to machine parts.

Turret indexing time
(1-station swivel)

0.15 sec

No. of tool station
(Upper+Lower turret)

20 {12+8} OPTION station

Radial BMT

The turret features BMT55P style tooling in which the toolholders are mounted directly to the turrets periphery using 4 large bolts.

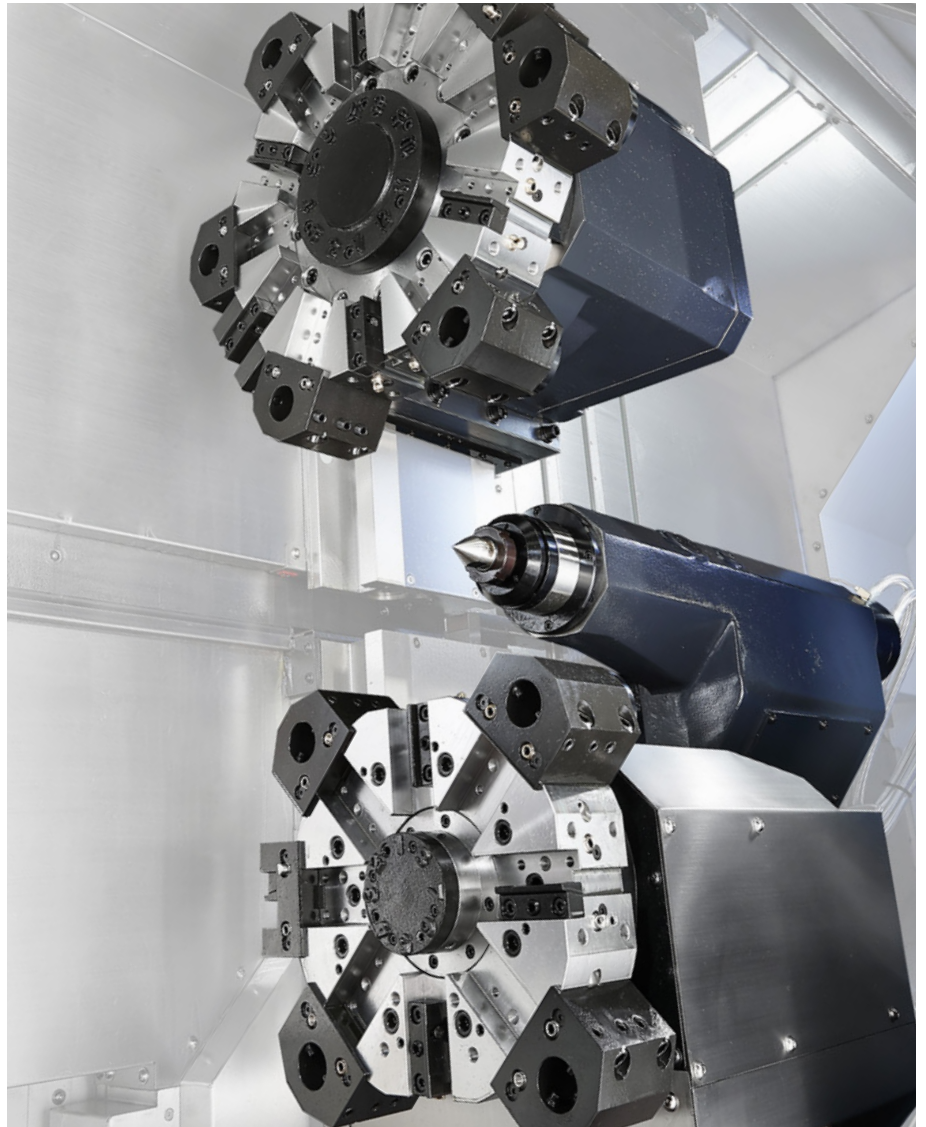
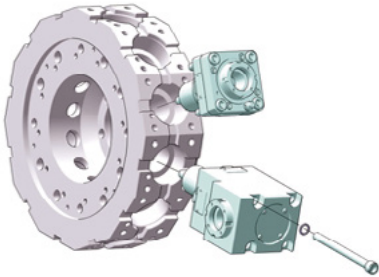

AXIS SYSTEM

Each axis is powered by a maintenance-free digital AC servo motor. These high-torque motors are connected to the ball screws without intermediate gears for quiet and responsive slide movement with virtually no backlash.

Rapid traverse rate (X/Z-axis)

20/24 m/min
(787.4/944.9 ipm)

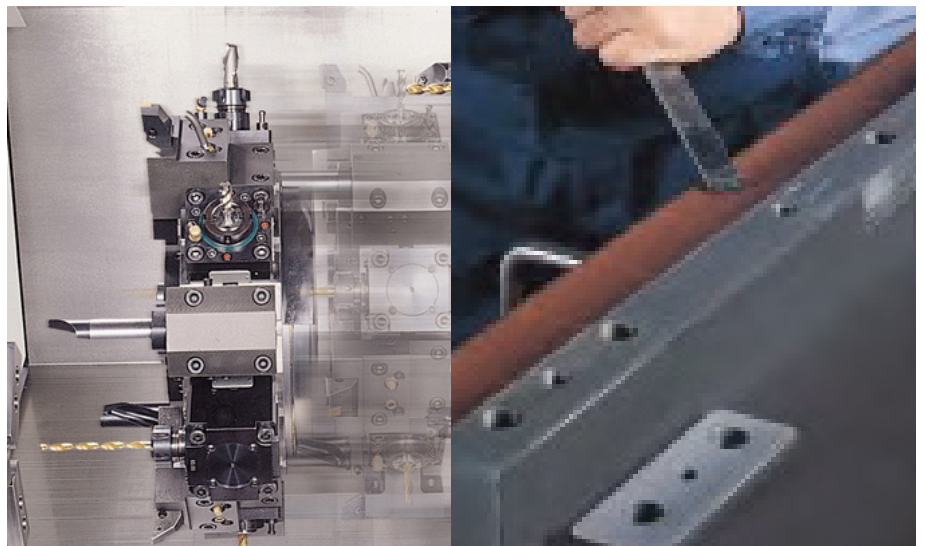

STANDARD | OPTIONAL SPECIFICATIONS

A range of options is available to suit individual requirements.

Description	Features	PUMA TL2000/2500series
Chuck	210 mm (8 inch)	PUMA TL2000
	255 mm (10 inch)	PUMA PUMA TL2500
	None	<input type="radio"/>
Jaws	Soft Jaws	<input checked="" type="radio"/>
	Hardened & Ground Hard Jaws	<input type="radio"/>
Chucking option	Dual Pressure Chucking	<input type="radio"/>
	Chuck Clamp Confirmation	<input type="radio"/>
Tailstock	Tailstock quill for built-in(dead) center	<input type="radio"/>
Coolant pump	1.5 bar	<input checked="" type="radio"/>
	4.5/7/10/14.5/20/70 bar	<input type="radio"/>
Coolant options	Oil Skimmer	<input type="radio"/>
	Coolant Chiller	<input type="radio"/>
	Coolant Pressure Switch	<input type="radio"/>
	Cooling Flow Switch	<input type="radio"/>
	High Coolant Interface	<input type="radio"/>
	Chuck Coolant	<input type="radio"/>
	Coolant Gun	<input type="radio"/>
Chip processing options	Chip Conveyor_Side Type	<input type="radio"/>
	Chip Conveyor_Rear Type	<input type="radio"/>
	Chip Bucket	<input type="radio"/>
	Air Blow	<input type="radio"/>
	Mist Collector	<input type="radio"/>
Measurement & Automation	Tool setter (Auto)	<input type="radio"/>
	Parts Catcher And Box	<input type="radio"/>
	Auto Door	<input type="radio"/>
	Robot Interface (PMC I/O, Profibus)	<input type="radio"/>
	Bar Feeder Interface	<input type="radio"/>
	Bar puller	<input type="radio"/>
Customized Special Option	V Stand For Shaft Workpiece	<input type="radio"/>
	Automatic Top Door	<input type="radio"/>
	Water soluble Coolant Chiller**	<input type="radio"/>
	Chip Conveyor_Drum Filter Type	<input type="radio"/>
	Shower Coolant	<input type="radio"/>
	Air Limit Sensing On Chuck Preparation	<input type="radio"/>
	Rotary Type Window Wiper_Eletrical	<input type="radio"/>
	TSC For Main/Left Spindle	<input type="radio"/>
	TSA For Main/Left Spindle	<input type="radio"/>
	Work & Tool Counter	<input type="radio"/>
	Tool Setter Extension For Special Chuck	<input type="radio"/>
	Main/Left Spindle Air Curtain	<input type="radio"/>
	MQL System	<input type="radio"/>
	Chuck Pressure Switch	<input type="radio"/>
	Coolant Level Switch : Sensing Level - Low	<input type="radio"/>
Quick Change Tooling(CAPTO)	<input type="radio"/>	

* Please contact your DN Solutions representative for detailed machine information.

* When using a semi-synthetic type or synthetic type, contact our sales representative or service center in advance.

** Technical consultation is mandatory for the chilling of non-water soluble coolant.

● Standard ○ Optional X/N/A

PERIPHERAL EQUIPMENT

Chip conveyor (right side) OPTION

The chip conveyor with its stable design delivers excellent chip disposal, superior operation and maintenance convenience. Users can select the optimum type of conveyor that meets their specific machining and floor space requirements.

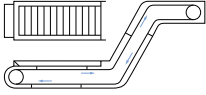
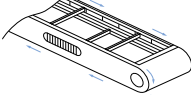
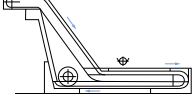
Name	Hinged belt	Magnetic scrapper	Drum filter (Single type)
Application	Steel	Cast steel, iron	Steel, cast, nonferrous metals
Features	<ul style="list-style-type: none"> • General use • Suitable for steel applications producing 30mm chips or longer 	<ul style="list-style-type: none"> • Easy-to-understand manual • Chips are scraped up and discharged 	<ul style="list-style-type: none"> • Suitable for long and short chips • Cooling water filtering function
Shape			

Coolant chiller (recommended) OPTION

A coolant chiller is recommended to help prevent temperature rises and to reduce thermal deformation when using a water-insoluble coolant or high-pressure coolant system (i.e., power over 1.5kW).

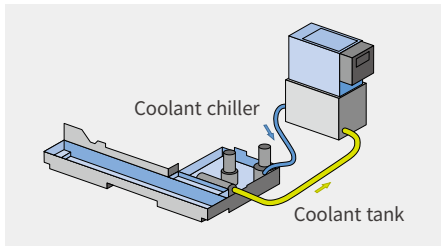

Quick change capto OPTION

The Quick-Change tool system simplifies tool change operations. Recommended for users who need to change tools frequently or who need to reduce set-up times.



Oil skimmer OPTION

The oil skimmer keeps coolant and lubricant isolated from each other for extending lifecycle of coolant.



Optional equipment

Auto tool setter



Coolant blower



Signal tower



Mist collector

The mist collector absorbs airborne oil vapor and fine dusts in the system to improve working environment



Part catcher

The part catcher automatically accepts parts completed of machining, and ejects them out of the system.

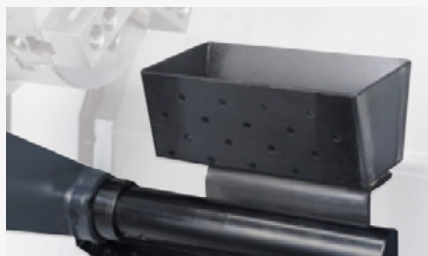

Collet chuck



DN SOLUTIONS FANUC i PLUS

DN Solutions Fanuc i Plus maximizes customer productivity and convenience.

15" Screen + New OP

DN Solutions Fanuc i Plus' operation panel enhances operating convenience by incorporating common-design buttons and layout. It features a Qwerty keyboard for fast and easy data input and operation.

DN Solutions Fanuc i Plus

- 15-inch color display
- Intuitive and user-friendly design

USB and PCMCIA card QWERTY keyboard

- EZ-Guide i standard
- Ergonomic operator panel
- 2MB Memory
- Hot keys



iHMI touchscreen OPTION

iHMI provides an intuitive interface that uses a touchscreen for quick and easy operation.

Range of applications

Providing various applications related to planning, machining, improvement and utility, for customer convenience.



NUMERIC CONTROL SPECIFICATIONS

FANUC

Division	Item	Specifications	2-Axis	M
			DN Solutions Fanuc i Plus	DN Solutions Fanuc i Plus
Controlled axis	Controlled axes		4 (X1,Z1,X2,Z2)	5 (X1,Z1,C1,X2,Z2)
	Simultaneously controlled axes		2 axes (each path)	3 axes (each path)
Data input/output	Fast data server		○	○
	Memory card input/output		●	●
	USB memory input/output		●	●
Interface function	Embedded Ethernet		●	●
	Fast Ethernet		○	○
	Enhanced Embedded Ethernet function		●	●
Operation	DNC operation	Included in RS232C interface.	●	●
	DNC operation with memory card		●	●
Program input	Workpiece coordinate system	G52 - G59	●	●
Feed function	AI contour control I	G5.1 Q_, 40 Blocks	●	●
	AI contour control II	G5.1 Q_, 200 Blocks	○	○
Operation Guidance Function	EZ Guidei (Conversational Programming Solution)		●	●
	iHMI with Machining Cycle	Note *1) Only with 15" Touch LCD standard	○ *1)	○ *1)
	Multi path function	Supporting 2 or 3 path machine	●	●
Setting and display	EZ Work		●	●
	CNC screen dual display function		●	●
Network	FANUC MTConnect		⊕	⊕
	FANUC OPC UA		⊕	⊕
Others	Display unit	15" color LCD	●	●
		15" color LCD with Touch Panel	○	○
	Part program storage size & Number of registerable programs	1280M(512KB)_1000 programs	X	X
		5120M(2MB)_1000 programs	●	●

DN SOLUTIONS FANUC i PLUS

EZ-Guide i

Using the DN Solutions EZ-Guide i, users can create a cutting program for any desired shape, including patterns, by entering just the dimensions.

Example programming : Cutting shape

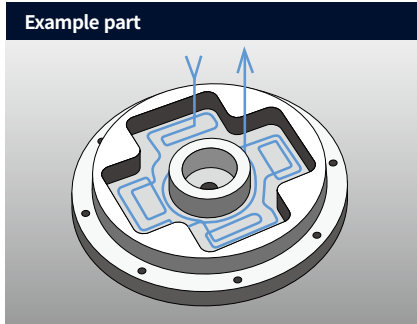
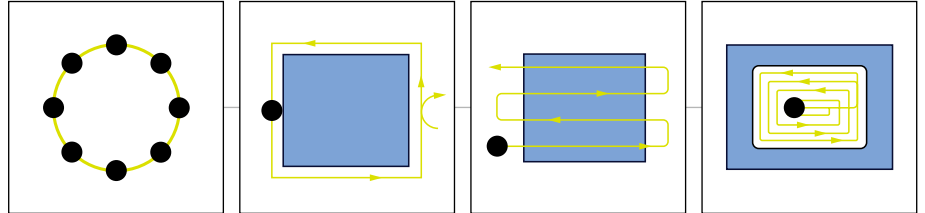

```

Automatic creation of cutting program

O7000 (SAMPLE PROGRAM) ;
...
M3 S1500 ;
G0 X50. Y125. ;
G0 Z30. ;
G1040 T0.5 J3. H0.2 K0.5 ... ;
G1020 H120. V50. U37. W68. ... ;
G0 Z80. ;
M5 ;
    
```

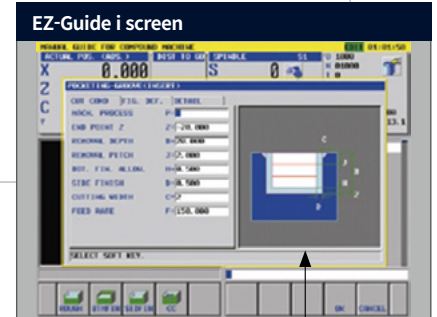

A cutting program is automatically created with the entered values.

Enter the dimensions of the shape.

EZ Work

DN Solutions's EZ Work supports the user with functions relating to tool data, error diagnostics, set up and machine monitoring.



Tool Load Monitoring Function

During cutting operation, abnormal load caused by wear or damage of the tool is detected and an alarm is triggered to prevent further damage.

Tool monitoring screen

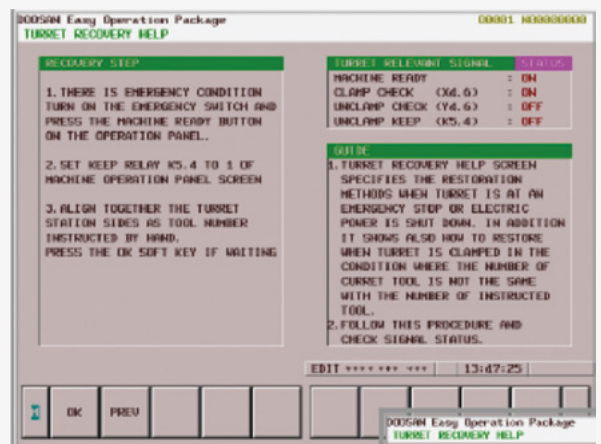

Convenience of Maintenance and Service

The condition and service procedures of the sensors are provided for easy maintenance and servicing of major units.

Turret maintenance and service screen

POWER | TORQUE

FANUC

PUMA TL2000/2000M

Max. spindle speed

5000 r/min

Max. power

22 kW
(29.5 Hp)

Max. torque

467 N·m
(344.6 ft-lbs)

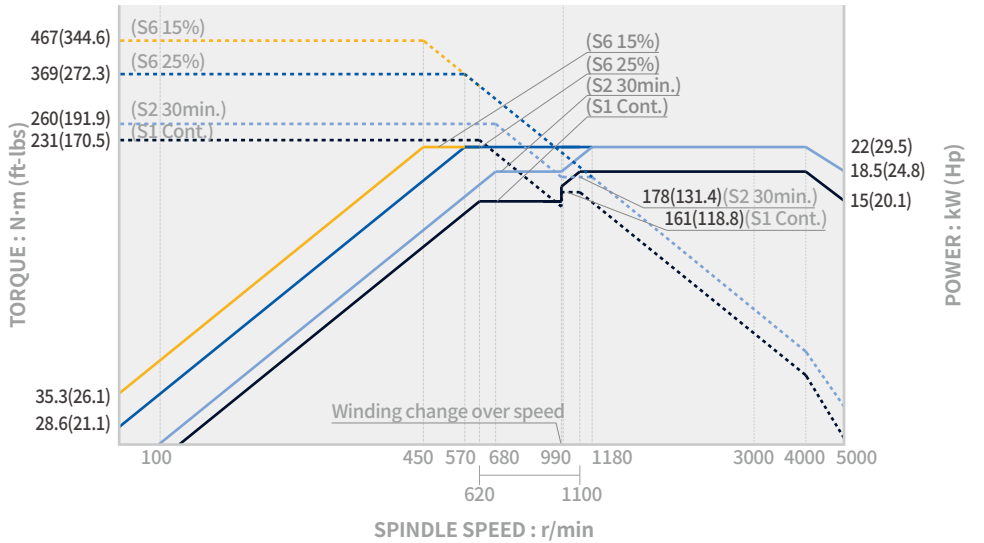

PUMA TL2500 Series

Max. spindle speed

4000 r/min

Max. power

26 kW
(34.9 Hp)

Max. torque

521 N·m
(384.5 ft-lbs)

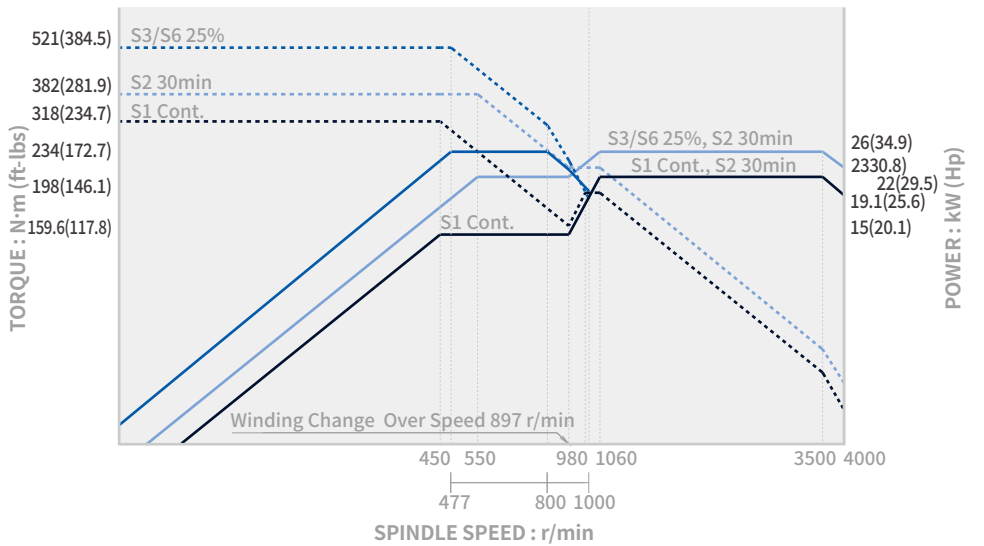

Rotary tool

Max. spindle speed

5000 r/min

Max. power

5.5 / 1.1 kW
(7.4 / 1.5 Hp)

Max. torque

47 N·m
(34.7 ft-lbs)

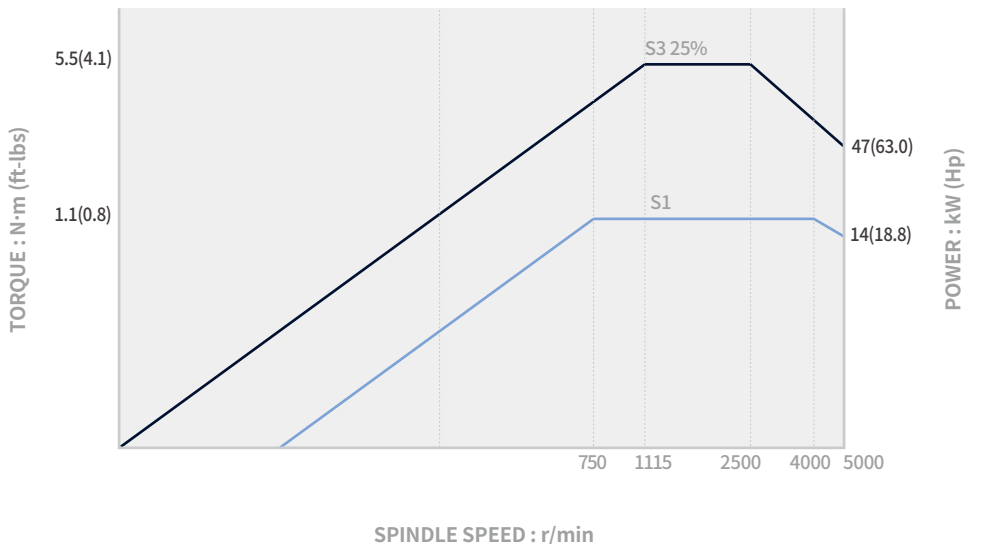

EXTERNAL DIMENSIONS

PUMA TL2000/2500

Unit : mm (inch)

TOP

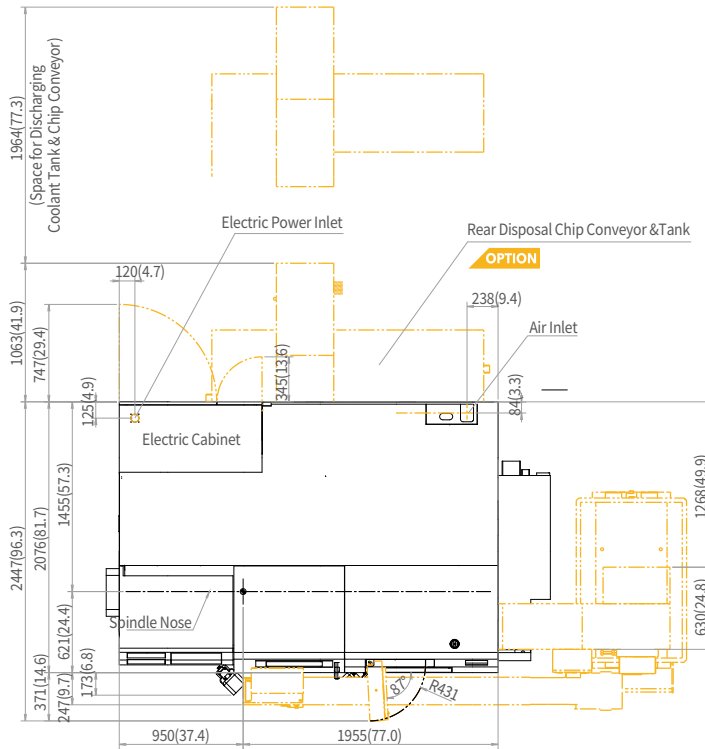

Model	Length 'A' (mm)
PUMA TL2000	55 (2.2)
PUMA TL2500	100 (3.9)

Chip disposal direction	Length 'B' (mm)
Side disposal	1110 (43.7)
Rear disposal	1170 (46.1)

FRONT

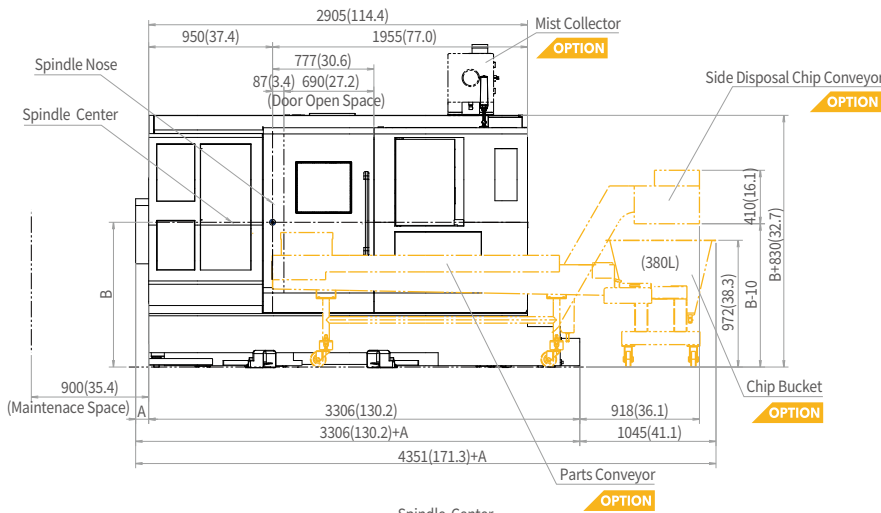

SIDE

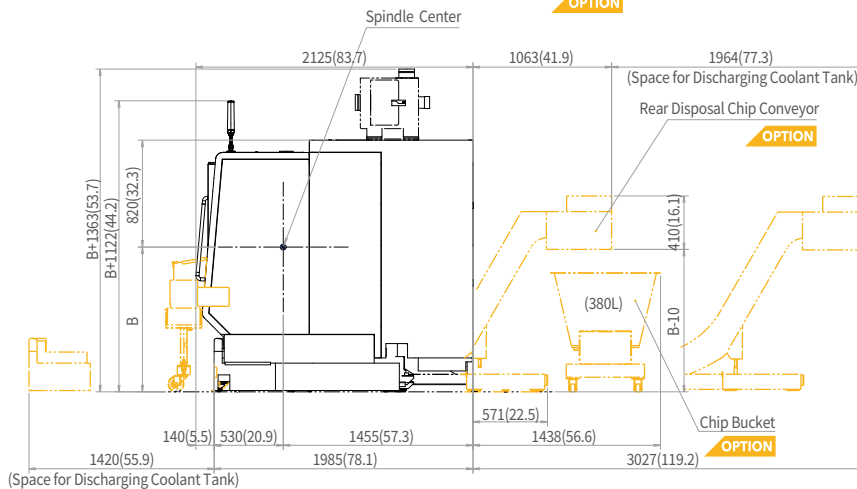

* Some peripheral equipment can be placed in other areas.

EXTERNAL DIMENSIONS

PUMA TL2000L/2500L

Unit : mm (inch)

TOP

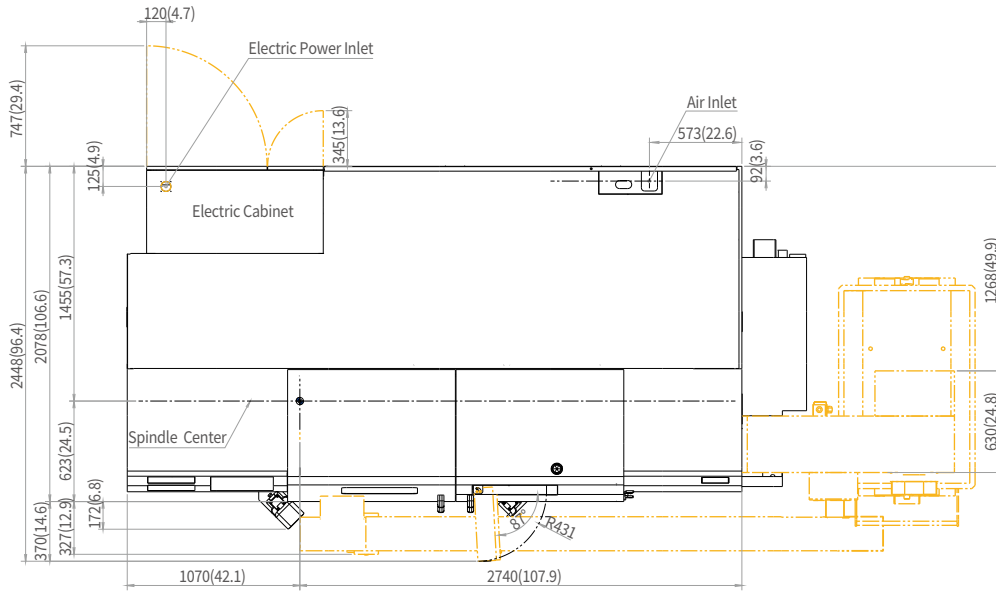

FRONT

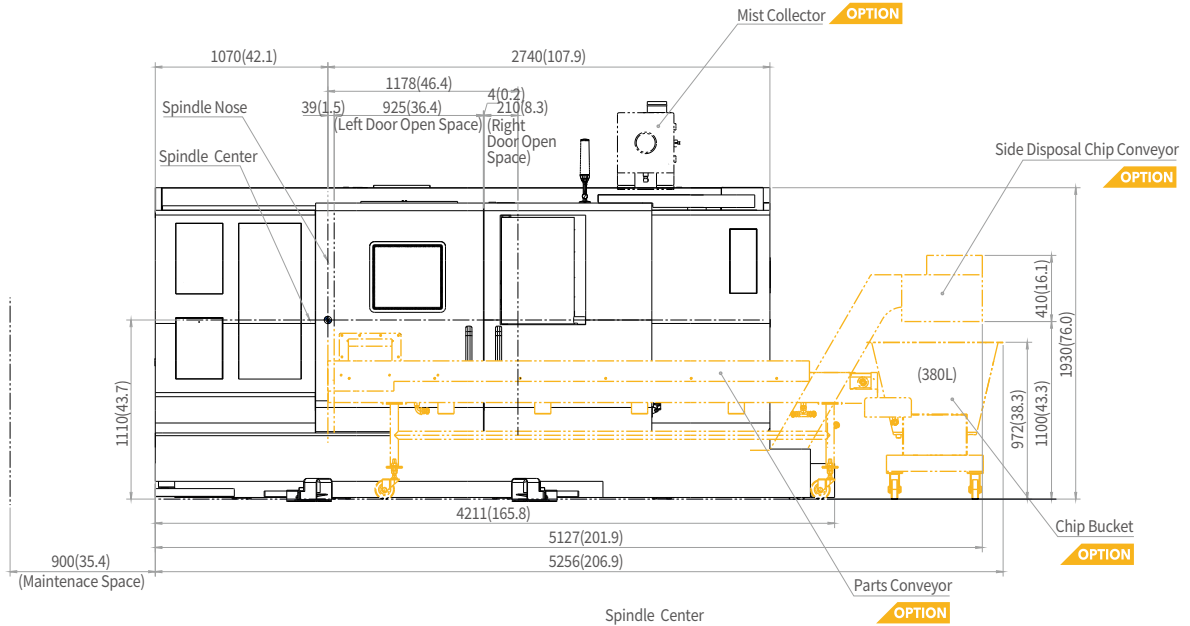

SIDE

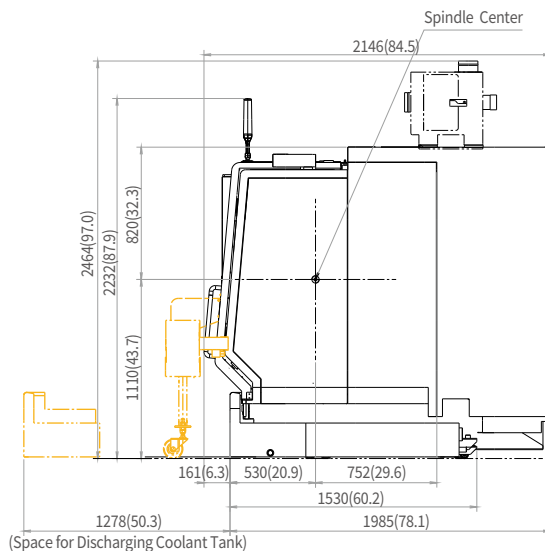

EXTERNAL DIMENSIONS

PUMA TL2500XL

Unit : mm (inch)

TOP

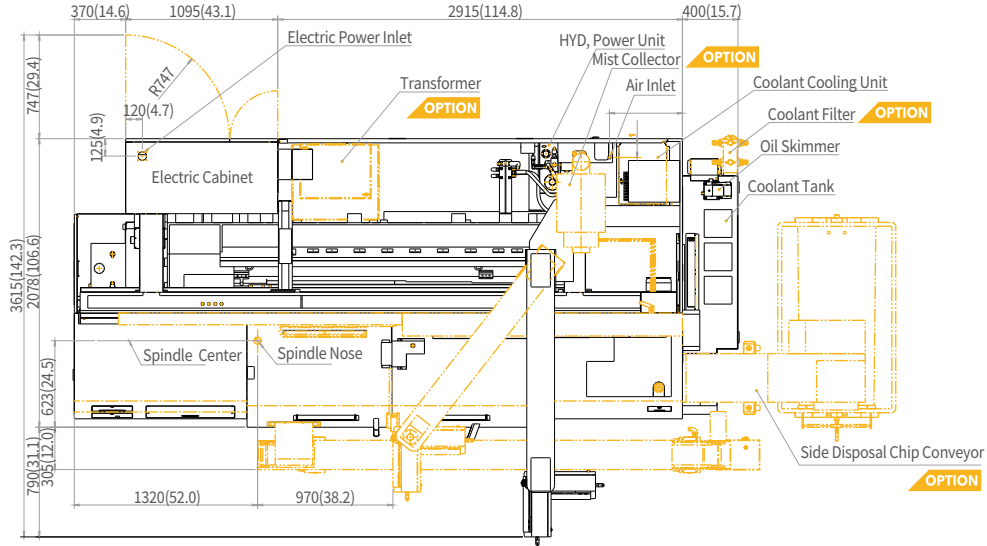

FRONT

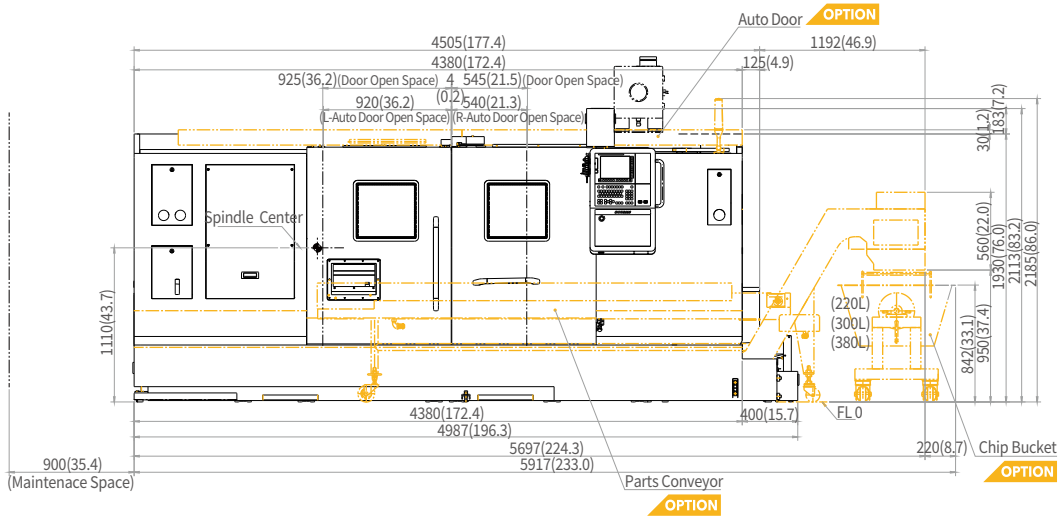

SIDE

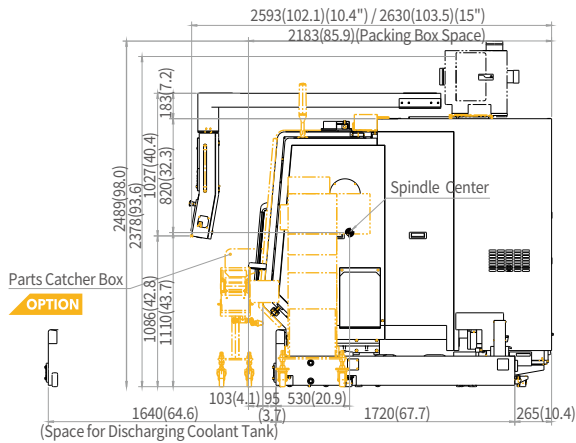

* Some peripheral equipment can be placed in other areas.

TOOLING SYSTEM

PUMA TL2000/2500 (Upper & Lower Turret)

Unit : mm (inch)

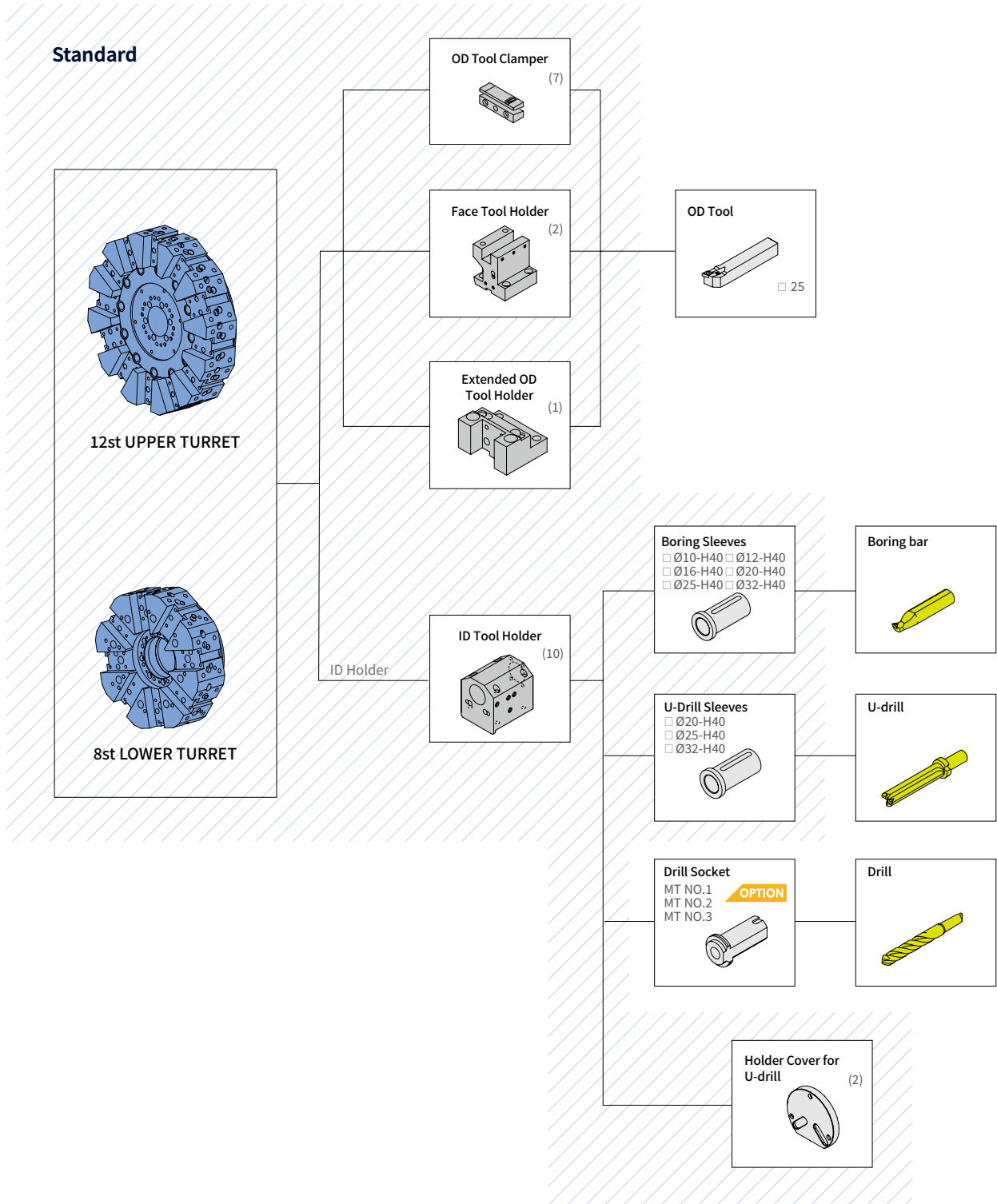

TOOLING SYSTEM

PUMA TL2000M/2500M (Upper & Lower Turret)

Unit : mm (inch)

Standard

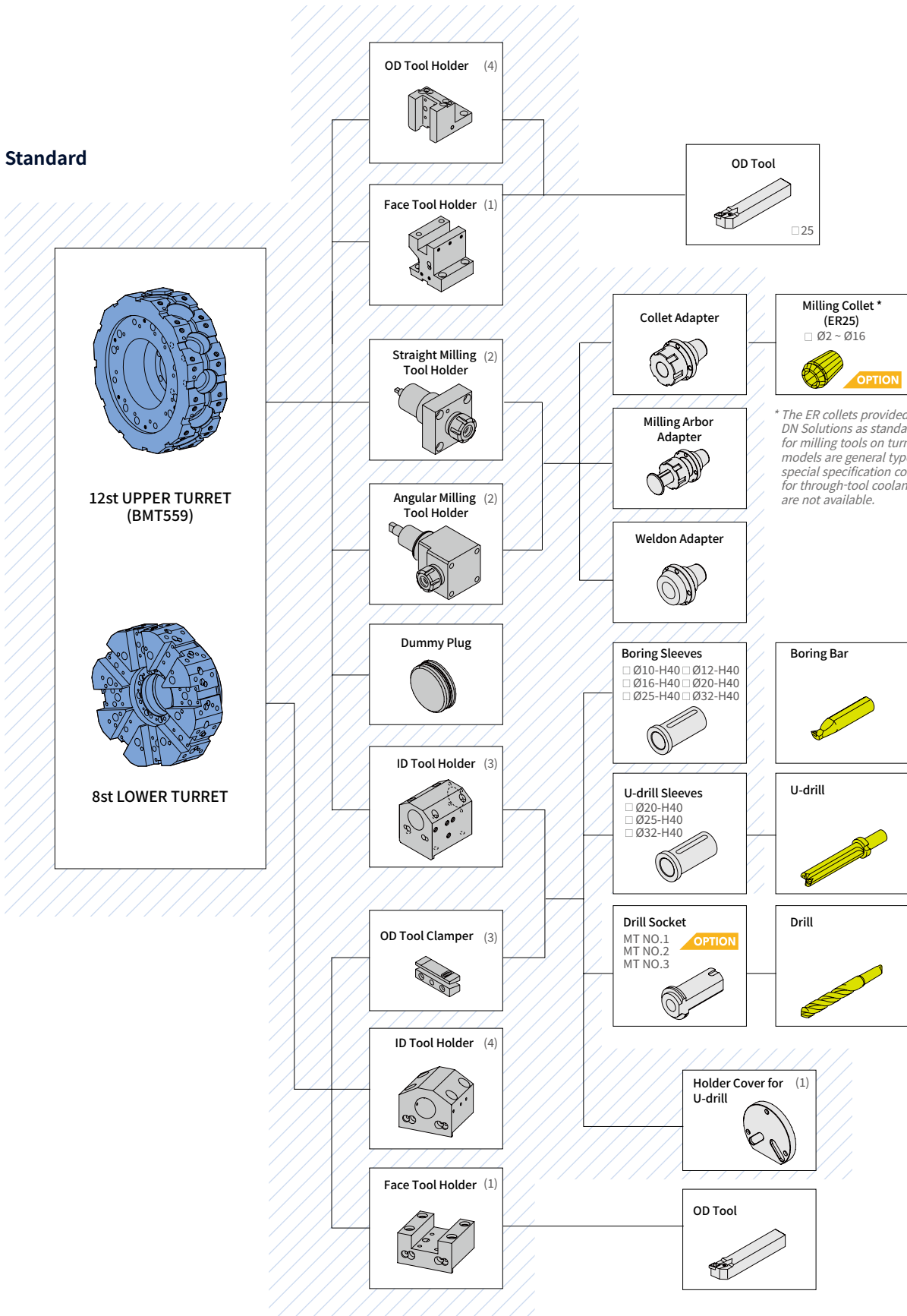

* The ER collets provided by DN Solutions as standard or optional for milling tools on turning center models are general type only, and special specification collets (such as for through-tool coolant or tapping) are not available.

MACHINE SPECIFICATIONS

PUMA TL2000/2500 series

Description		Unit	PUMA TL2000 [L]	PUMA TL2000M [LM]	PUMA TL2500 [L/XL]	PUMA TL2500M [LM/XLM]	
Capacity	Swing over bed	mm (inch)	600 (23.6)				
	Swing over saddle(Upper)	mm (inch)	430 (16.9)				
	Recom. Turning diameter	mm (inch)	210 (8.3)		255 (10.0)		
	Max. Turning diameter (Upper/Lower turret)	mm (inch)	370/240 (14.6/9.4)	350/240 (13.8/9.4)	370/240 (14.6/9.4)	350/240 (13.8/9.4)	
	Max. Turning length	mm (inch)	600 [1000/1250] (23.6 [39.4/49.2])				
	Bar working diameter	mm (inch)	ø65 (2.6)		ø81 (3.2)		
Feedrate	Travel distance	X1 / 2-axis	mm (inch) X1 : 250 (9.8) / X2 : 150 (5.9)				
		Z1 / 2-axis	mm (inch) Z1 : 650 [1050/1300] (25.6 [41.3/51.2]) / Z2 : 630[1030/1280](24.8 [40.6/50.4])				
	Rapid traverse	X1 / 2-axis	m/min (ipm) 20 (787.4)				
		Z1 / 2-axis	m/min (ipm) 24 (944.9)				
Spindle	Spindle speed	r/min	5000		4000		
	Spindle nose	ASA	A2#6		A2#8		
	Spindle bearing diameter (Front)	mm (inch)	110 (4.3)		130 (5.1)		
	Spindle through hole diameter	mm (inch)	76 (3.0)		91 (3.6)		
	Cs Spindle Index angle	deg	-	360 (in 0.001deg.increment)		-	360 (in 0.001deg.increment)
Motor	Left spindle motor(Int.)	kW (Hp)	22/22/18.5/15 kW (S6 15%/S6 25%/S2 30min/S1 Cont.)		26/22/15 kW (S6 25%/S2 30min/S1 Cont.)		
	Rotary tool spindle motor*	kW (Hp)	-	5.5 (7.4)		-	5.5 (7.4)
	Servo motor	X1-axis	kW (Hp)	3.0 (4.0)			
		X2-axis	kW (Hp)	1.6 (2.1)			
		Z1-axis	kW (Hp)	3.0 (4.0)			
		Z2-axis	kW (Hp)	3.0 (4.0)			
Coolant Pump	kW	0.4					
Turret	No. of tool stations	ea	12(Upper) + 8(Lower)				
	OD tool height	mm (inch)	25 (1.0)				
	Boring bar diameter	mm (inch)	40 (1.6)				
	Indexing time	sec	0.15				
	Rotary tool spindle speed*	r/min	-	5000		-	5000
Tail Stock	Quill diameter	mm (inch)	100 (3.9)				
	Quill bore taper	ASA	MT#5				
	Quill travel	mm (inch)	120 (4.7)				
Power Source	Power consumption	kVA	39.37	40.7	47.84	49.17	
Machine dimensions	Length	mm (inch)	3250 [3900/4510] (128.0 [153.5/177.6])				
	Width	mm (inch)	2118 [2144/2630] (83.4 [84.4/103.5])				
	Height	mm (inch)	1930 (76.0) [PUMA 2500XL/XLM: 2115(83.3)]				
	Weight	kg (lb)	7200 [8400] (15432.1 [18518.6])		7300 [8500/9600 (PUMA TL2500XL)/9700(PUMA TL2500XLM)] (16093.5 [18739.0(PUMA TL2500XL)/(21164.1 (PUMA TL2500XLM))])		
Control	NC system	-	DN Solutions Fanuc i Plus [Fanuc 31i]				

WHY DN SOLUTIONS

The DN Solutions promise, MACHINE GREATNESS, has two important meanings. The first is simple: DN Solutions makes great machines. The second is a challenge to our end-users. With a product line that is this comprehensive, accurate and reliable, we equip our customers to machine greatness. The big question: *Why should you choose DN Solutions over other options?* Here's why...

UNBEATABLE MACHINES

You won't find a more comprehensive range or a better combination of value, performance and reliability anywhere else.

ROBUST PRODUCT LINE

We offer an impressive range of machine models and hundreds of configurations. Whatever your machining needs and requirements, there's a DN Solutions for you.

READILY AVAILABLE - ANYWHERE IN THE WORLD

Machining centres (including 5-axis machines), lathes, multi-tasking turning centres and mill-turn machines, and horizontal borers with best-in-class specifications are all available...ready to install.

EXPERT SERVICE

Our dedicated, experienced and knowledgeable team is totally committed to improving your productivity, growth and success.

CUSTOMER SUPPORT AND SERVICES

WE'RE THERE FOR YOU WHENEVER YOU NEED US.

We help our customers operate at maximum efficiency by providing them with a range of tried, tested and trusted services - from pre-sales consultancy to post-sales support.



FIELD SERVICES

- On-site service
- Machine installation and testing
- Scheduled preventive maintenance
- Machine repair service



PARTS SUPPLY

- Supplying a wide range of original DN Solutions spare parts
- Parts repair service



TRAINING

- Programming, machine setup and operation
- Electrical and mechanical maintenance
- Applications engineering

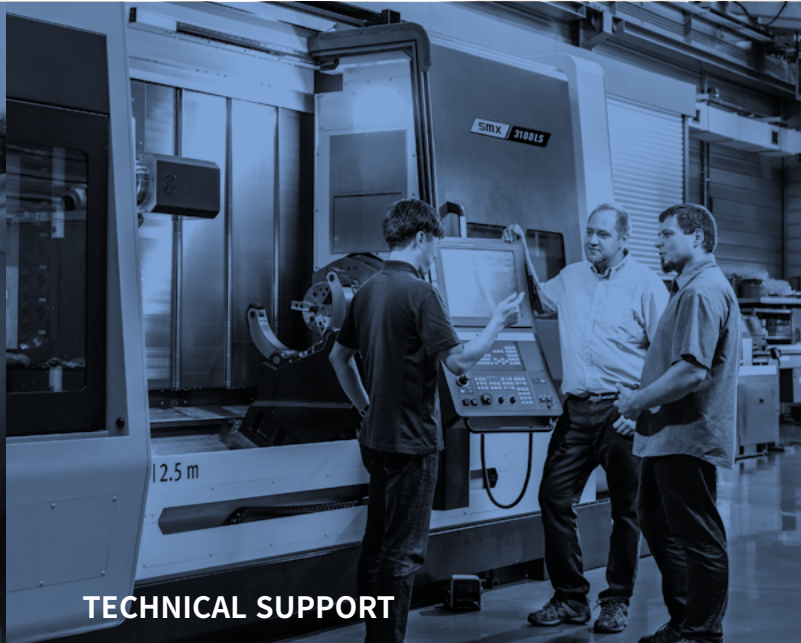

TECHNICAL SUPPORT

- Supports machining methods and technology
- Responds to technical queries
- Provides technical consultancy

RESPONDING TO CUSTOMERS **ANYTIME, ANYWHERE**

DN SOLUTIONS GLOBAL NETWORK

DN Solutions provides systems-based professional support services, before and after the machine tool sale, by responding quickly and efficiently to customers. By supplying spare parts, product training, field service and technical support, we provide the expert care, attention and assistance our customers expect from a market leader.



66	COUNTRIES
140+	SALES NETWORKS
3	FACTORIES
6	REGIONAL HQS



**Head Office**

19F, 10, Tongil-ro, Jung-gu, Seoul,
Republic of Korea, 04527

Tel: +82-2-6972-0370
Fax: +82-2-6972-0400

DN Solutions America

360 E State PKWY,
Schaumburg, IL. 60173,
United states

Tel: +1-315-265-7500

DN Solutions Europe

Emdener Strasse 24, D-41540
Dormagen, Germany

Tel: +49-2133-5067-100
Fax: +49-2133-5067-111

DN Solutions India

No.82, Jakkur Village
Yelahanka Hobli,
Bangalore-560064

Tel: +91-80-2205-6900
E-mail: india@dncompany.com

DN Solutions China

Room 101,201,301,
Building 39 Xinzhuan Highway
No.258 Songjiang District
China Shanghai (201612)

Tel: +86 21-5445-1155
Fax: +86 21-6405-1472

DN Solutions Vietnam

M.O.R.E building 2F, 40A-40B Ut
Tich Street, 04 Ward 04,
District Tan Binh District,
Ho Chi Minh City, Vietnam

Tel: +84 28-7304-0163

DN Solutions Mexico

Avenida Parque Bicentenario
#100 Nave M65L3-6,
Fraccionamiento San Isidro
Business Park,
Santa Rosa Jauregui,
Querétaro, México

E-mail: efrain.figueroa@dncompany.com

Sales inquiry

sales@dncompany.com